

# Eliwell ET6 Touch Panel

## User Manual

9MA10321.00  
09/2025

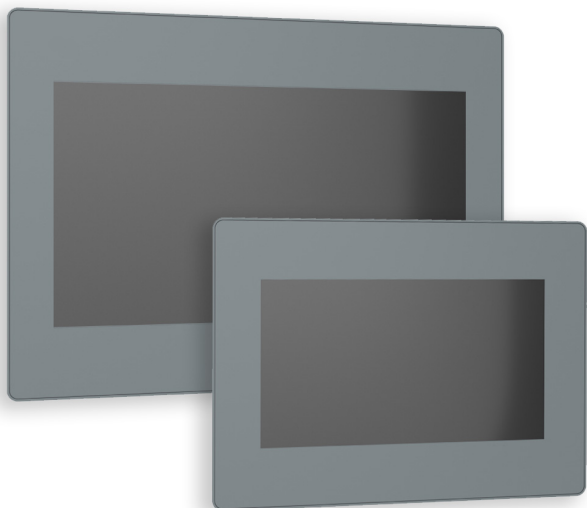

# Legal Information

The information provided in this document contains general descriptions, technical characteristics and/or recommendations related to products/solutions.

This document is not intended as a substitute for a detailed study or operational and site-specific development or schematic plan. It is not to be used for determining suitability or reliability of the products/solutions for specific user applications. It is the duty of any such user to perform or have any professional expert of its choice (integrator, specifier or the like) perform the appropriate and comprehensive risk analysis, evaluation and testing of the products/solutions with respect to the relevant specific application or use thereof.

The Schneider Electric brand and any trademarks of Schneider Electric SE and its subsidiaries referred to in this document are the property of Schneider Electric SE or its subsidiaries. All other brands may be trademarks of their respective owner.

This document and its content are protected under applicable copyright laws and provided for informative use only. No part of this document may be reproduced or transmitted in any form or by any means (electronic, mechanical, photocopying, recording, or otherwise), for any purpose, without the prior written permission of Schneider Electric.

Schneider Electric does not grant any right or license for commercial use of the document or its content, except for a non-exclusive and personal license to consult it on an "as is" basis.

Schneider Electric reserves the right to make changes or updates with respect to or in the content of this document or the format thereof, at any time without notice.

**To the extent permitted by applicable law, no responsibility or liability is assumed by Schneider Electric and its subsidiaries for any errors or omissions in the informational content of this document, as well as any non-intended use or misuse of the content thereof.**

---

# Table of Contents

Safety Information .....	5
About the Document .....	6
Overview .....	13
Part Numbers .....	13
Package Contents .....	13
Certifications and Standards .....	14
Device Connectivity .....	16
System Design .....	16
Parts Identification and Functions .....	17
Parts Identification .....	17
LED Indications .....	19
Specifications .....	20
General Specifications .....	20
Electrical Specifications .....	20
Environmental Specifications .....	20
Structural Specifications .....	21
Functional Specifications .....	23
Display Specifications .....	23
Touch Panel .....	23
Memory .....	23
Clock .....	24
Interface Specifications .....	25
Specifications of Each Interface .....	25
Serial Interface .....	25
Dimensions .....	28
HMIET6400E and HMIET6401E External Dimensions .....	28
HMIET6500E and HMIET6501E External Dimensions .....	29
Installing and Wiring .....	30
Installation .....	30
Precautions for Building into an End-use Product .....	30
Installation Requirements .....	30
Panel Cut Dimensions .....	32
Installation Procedure .....	32
Removal Procedure .....	35
Wiring the Power Supply .....	36
DC Power Cord Preparation .....	36
How to Connect the DC Power Cord .....	36
Power Supply Precautions .....	38
Grounding .....	39
USB Cable Clamp .....	41
Attaching USB Clamp Type A .....	41
Removing USB Clamp Type A .....	42
Attaching USB Clamp mini-B .....	42
Removing USB Clamp mini-B .....	43
Maintenance .....	44
Regular Cleaning .....	44
Periodic Check Points .....	44
Replacing the Battery .....	45



# Safety Information

## Important Information

Read these instructions carefully, and look at the equipment to become familiar with the device before trying to install, operate, service, or maintain it. The following special messages may appear throughout this documentation or on the equipment to warn of potential hazards or to call attention to information that clarifies or simplifies a procedure.





The addition of this symbol to a “Danger” or “Warning” safety label indicates that an electrical hazard exists which will result in personal injury if the instructions are not followed.



This is the safety alert symbol. It is used to alert you to potential personal injury hazards. Obey all safety messages that follow this symbol to avoid possible injury or death.

 <b>DANGER</b>
<b>DANGER</b> indicates a hazardous situation which, if not avoided, <b>will result in</b> death or serious injury.

 <b>WARNING</b>
<b>WARNING</b> indicates a hazardous situation which, if not avoided, <b>could result in</b> death or serious injury.

 <b>CAUTION</b>
<b>CAUTION</b> indicates a hazardous situation which, if not avoided, <b>could result in</b> minor or moderate injury.

<b>NOTICE</b>
<b>NOTICE</b> is used to address practices not related to physical injury.

## Please Note

Electrical equipment should be installed, operated, serviced, and maintained only by qualified personnel. No responsibility is assumed by Schneider Electric for any consequences arising out of the use of this material.

A qualified person is one who has skills and knowledge related to the construction and operation of electrical equipment and its installation, and has received safety training to recognize and avoid the hazards involved.

# About the Document

## Document Scope

The Eliwell ET6 Touch Panel User Manual provides detailed guidance on the installation, operation, and maintenance of the HMIET6•••0E models. It outlines product specifications including display type, touch panel features, memory capacity, and interface options. The document emphasizes proper handling and installation techniques to ensure optimal performance and longevity of the device.

## Validity Note

This documentation is valid for this product.

The characteristics of the products described in this document are intended to match the characteristics that are available on [www.se.com](http://www.se.com). As part of our corporate strategy for constant improvement, we may revise the content over time to enhance clarity and accuracy. If you see a difference between the characteristics in this document and the characteristics on [www.se.com](http://www.se.com), consider [www.se.com](http://www.se.com) to contain the latest information.

## Product Related Information

If the equipment is used in a manner not specified by the manufacturer, the protection provided by the equipment may be impaired.

### **DANGER**

#### **HAZARD OF ELECTRIC SHOCK, EXPLOSION, OR ARC FLASH**

- Remove all power from the device before removing any covers or elements of the system, and prior to installing or removing any accessories, hardware, or cables.
- Unplug the power cable from both this product and the power supply prior to installing or removing the product.
- Always use a properly rated voltage sensing device to confirm power is off where and when indicated.
- Replace and secure all covers or elements of the system before applying power to this product.
- Use only the specified voltage when operating this product. This product is designed to use 24 Vdc. Always check whether your device is DC powered before applying power.

**Failure to follow these instructions will result in death or serious injury.**

**⚠ DANGER****EXPLOSION HAZARD**

- Do not use this product in hazardous environments.
- Do not connect or disconnect this product unless power has been switched off or the area is known to be non-hazardous.
- Do not attempt to install, operate, modify, maintain, service, or otherwise alter this product except as permitted in this manual.
- Confirm that the USB cable has been attached with the USB cable clamp before using the USB interface.
- Use the USB (micro-B) interface for temporary connection only during maintenance and setup of the device.

**Failure to follow these instructions will result in death or serious injury.**

Critical alarm indicators and system functions require independent and redundant protection hardware and/or mechanical interlocks.

When you cycle power, wait at least 10 seconds after it has been turned off. If this product is restarted too quickly, it may not operate correctly.

In the event the screen cannot be properly read, for example, if the backlight is not functioning, it may be difficult or impossible to identify a function. Functions that may present a hazard if not immediately executed, such as a fuel shut-off, must be provided independently of this product. The machine's control system design must take into account the possibility of the backlight no longer functioning and the operator being unable to control the machine or making mistakes in the control of the machine.

**⚠ WARNING****LOSS OF CONTROL**

- The designer of any control scheme must consider the potential failure modes of control paths and, for certain critical control functions, provide a means to achieve a safe state during and after a path failure. Examples of critical control functions are emergency stop and overtravel stop, power outage and restart.
- Separate or redundant control paths must be provided for critical control functions.
- System control paths may include communication links. Consideration must be given to the implications of unanticipated transmission delays or failures of the link.
- Observe all accident prevention regulations and local safety guidelines.
- Each implementation of this product must be individually and thoroughly tested for proper operation before being placed into service.
- The machine control system design must take into account the possibility of the backlight no longer functioning and the operator being unable to control the machine, or making errors in the control of the machine.

**Failure to follow these instructions can result in death, serious injury, or equipment damage.**

For additional information, refer to NEMA ICS 1.1 (latest edition), "Safety Guidelines for the Application, Installation, and Maintenance of Solid State Control" and to NEMA ICS 7.1 (latest edition), "Safety Standards for Construction and Guide for Selection, Installation and Operation of Adjustable-Speed Drive Systems" or their equivalent governing your particular location.

**⚠ WARNING****UNINTENDED EQUIPMENT OPERATION**

- The application of this product requires expertise in the design and programming of control systems. Only persons with such expertise should be allowed to program, install, alter, and apply this product.
- Follow all local and national safety standards.

**Failure to follow these instructions can result in death, serious injury, or equipment damage.**

**⚠ WARNING****UNINTENDED EQUIPMENT OPERATION**

- Do not use this product as the only means of control for critical system functions such as motor start/stop or power control.
- Do not use this equipment as the only notification device for critical alarms, such as device overheating or overcurrent.
- Use only the software provided with this product. If you use other software, please confirm the operation and safety before use.

**Failure to follow these instructions can result in death, serious injury, or equipment damage.**

The following characteristics are specific to the LCD panel and are considered normal behavior:

- LCD screen may show unevenness in the brightness of certain images or may appear different when seen from outside the specified viewing angle. Extended shadows, or crosstalk may also appear on the sides of screen images.
- LCD screen pixels may contain black and white colored spots and color display may seem to have changed.
- When experiencing vibrations within a certain frequency range and vibration acceleration is above what is acceptable, the LCD screen may partially turn white. Once the vibration condition ends, the whitening of the screen is resolved.
- When the same image is displayed on the screen for a long period, an afterimage may appear when the image is changed.
- The panel brightness may decrease when used for a long time in an environment continuously filled with inert gas. To prevent deterioration of panel brightness, regularly ventilate the panel.

**NOTE:** Change the screen image periodically and try not to display the same image for a long period of time.

**⚠ WARNING****SERIOUS EYE AND SKIN INJURY**

The liquid in the LCD panel contains an irritant:

- Avoid direct skin contact with the liquid.
- Wear gloves when you handle a broken or leaking unit.
- Do not use sharp objects or tools in the vicinity of the LCD panel.
- Handle the LCD panel carefully to prevent puncture, bursting, or cracking of the panel material.
- If the panel is damaged and any liquid comes in contact with your skin, immediately rinse the area with running water for at least 15 minutes. If the liquid gets in your eyes, immediately rinse your eyes with running water for at least 15 minutes and consult a doctor.

**Failure to follow these instructions can result in death, serious injury, or equipment damage.**

## General Cybersecurity Information

In recent years, the growing number of networked machines and production plants has seen a corresponding increase in the potential for cyber threats, such as unauthorized access, data breaches, and operational disruptions. You must, therefore, consider all possible cybersecurity measures to help protect assets and systems against such threats.

To help keep your Schneider Electric products secure and protected, it is in your best interest to implement the cybersecurity best practices as described in the [Cybersecurity Best Practices](#) document.

Schneider Electric provides additional information and assistance:

- [Subscribe to the Schneider Electric security newsletter.](#)
- [Visit the Cybersecurity Support Portal web page to:](#)
  - [Find Security Notifications.](#)
  - [Report vulnerabilities and incidents.](#)
- [Visit the Schneider Electric Cybersecurity and Data Protection Posture web page to:](#)
  - [Access the cybersecurity posture.](#)
  - [Learn more about cybersecurity in the cybersecurity academy.](#)
  - [Explore the cybersecurity services from Schneider Electric.](#)

## Environmental Data

For product compliance and environmental information, refer to the [Schneider Electric Environmental Data Program](#).

## Related Documents

Title of documentation	Reference number
Cybersecurity Best Practices	Refer to <a href="#">General Cybersecurity Information</a> , page 9

You can download these technical publications, the present document and other technical information from our website [www.eliwell.com](http://www.eliwell.com).

## Information on Non-Inclusive or Insensitive Terminology

As a responsible, inclusive company, Schneider Electric is constantly updating its communications and products that contain non-inclusive or insensitive terminology. However, despite these efforts, our content may still contain terms that are deemed inappropriate by some customers.

## Terminology Derived from Standards

The technical terms, terminology, symbols and the corresponding descriptions in the information contained herein, or that appear in or on the products themselves, are generally derived from the terms or definitions of international standards.

In the area of functional safety systems, drives and general automation, this may include, but is not limited to, terms such as *safety*, *safety function*, *safe state*, *fault*, *fault reset*, *malfunction*, *failure*, *error*, *error message*, *dangerous*, etc.

Among others, these standards include:

Standard	Description
IEC 61131–2:2007	Programmable controllers, part 2: Equipment requirements and tests.
ISO 13849–1:2023	Safety of machinery: Safety related parts of control systems. General principles for design.
EN 61496–1:2013	Safety of machinery: Electro-sensitive protective equipment. Part 1: General requirements and tests.
ISO 12100:2010	Safety of machinery — General principles for design — Risk assessment and risk reduction.
EN 60204–1:2006	Safety of machinery — Electrical equipment of machines — Part 1: General requirements.
ISO 14119:2013	Safety of machinery — Interlocking devices associated with guards — Principles for design and selection.
ISO 13850:2015	Safety of machinery — Emergency stop — Principles for design.
IEC 62061:2021	Safety of machinery — Functional safety of safety-related electrical, electronic, and electronic programmable control systems.
IEC 61508–1:2010	Functional safety of electrical/electronic/programmable electronic safety-related systems: General requirements.
IEC 61508–2:2010	Functional safety of electrical/electronic/programmable electronic safety-related systems: Requirements for electrical/electronic/programmable electronic safety-related systems.
IEC 61508–3:2010	Functional safety of electrical/electronic/programmable electronic safety-related systems: Software requirements.
IEC 61784–3:2021	Industrial communication networks — Profiles — Part 3: Functional safety fieldbuses — General rules and profile definitions.
2006/42/EC	Machine Directive
2014/30/EU	Electromagnetic Compatibility Directive
2014/35/EU	Low Voltage Directive

In addition, terms used in the present document may tangentially be used as they are derived from other standards such as:

Standard	Description
IEC 60034 series	Rotating electrical machines.
IEC 61800 series	Adjustable speed electrical power drive systems.
IEC 61158 series	Digital data communications for measurement and control — Fieldbus for use in industrial control systems.

Finally, the term *zone of operation* may be used in conjunction with the description of specific hazards, and is defined as it is for a *hazard zone* or *danger zone* in the *Machinery Directive (2006/42/EC)* and *ISO 12100:2010*.

**NOTE:** The aforementioned standards may or may not apply to the specific products cited in the present documentation. For more information concerning the individual standards applicable to the products described herein, see the characteristics tables for those product references.

## Registered Trademarks

Microsoft® and Windows® are registered trademarks of Microsoft Corporation in the United States and/or other countries.

Product names used in this manual may be the registered trademarks owned by the respective proprietors.



# Overview

## What's in This Chapter

Part Numbers..... 13  
 Package Contents ..... 13  
 Certifications and Standards ..... 14

## Part Numbers

### Part Number List

Series	Part name	Part number
Eliwell ET6 Touch Panel	HMIET6400E	HMIET6400E
	HMIET6401E	HMIET6401E
	HMIET6500E	HMIET6500E
	HMIET6501E	HMIET6501E

**NOTE:** All part numbers may be followed by any letter or number.

## Part Number Configuration

The following describes the configuration of model numbers.

Digit position								
1	2	3	4	5	6	7	8	9
H	M	I	(model)		(series)	(size)	(type)	
			ET		6	4: 7" Wide 5: 10" Wide	00: Standard 01: SIO (no Ethernet port)	

## Package Contents

Verify all items listed here are present in your package.

**NOTE:** This product has been carefully packed with special attention to quality. However, should you find anything damaged or missing, please contact your local distributor immediately.

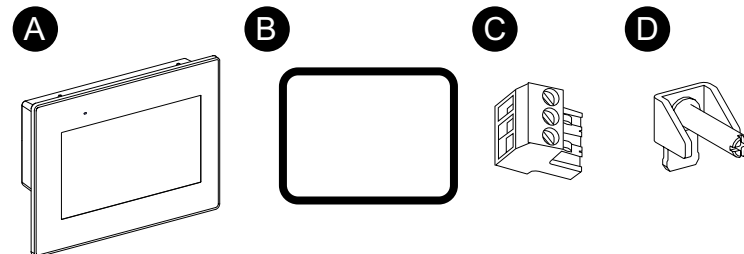

- A. Eliwell ET6 Touch Panel x 1
- B. Installation gasket (attached to this product) x 1
- C. DC power connector x 1
- D.
  - Installation fasteners x 4 (for HMIET6400E/HMIET6401E)

- Installation fasteners x 6 (for HMIET6500E/HMIET6501E)

## Revision and QR Code for Manual

You can identify the product version (PV) and the software version (SV) from the product label.

You can also check the contents of this manual by using the QR code on the product label. Confirm the location of the QR code below and refer to the manual.

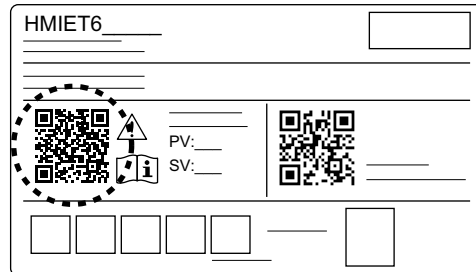

## Certifications and Standards

The certifications and standards listed below may include those that are not yet acquired. Please check the product marking for the latest acquisition status.

### Agency Certifications

Underwriters Laboratories Inc., UL 61010-2-201 and CSA C22.2 N°61010-2-201, for Industrial Control Equipment used in Ordinary Location

### Compliance Standards

Europe:

CE

- Directive 2014/35/EU (Low Voltage)
- Directive 2014/30/EU (EMC)

Korea:

- KC

Russia, Belarus, Kazakhstan:

- EAC

### Hazardous Substances

This product is designed to be compliant with the following environmental regulations, even if the product may not fall directly in the scope of the regulation:

- RoHS, Directive 2011/65/EU and 2015/863/EU
- RoHS China, Standard GB/T 26572
- REACH regulation EC 1907/2006

## End of Life (WEEE)

The product contains electronic boards. It must be disposed of in specific treatment channels. The product contains cells and/or storage batteries which must be collected and processed separately when they have run out and at the end of product life (Directive 2012/19/EU).

Refer to Maintenance, page 44 when extracting cells and batteries from the product. These batteries do not contain a weight percentage of heavy metals over the threshold notified by European Directive 2006/66/EC.

## KC Markings

기종별	사용자안내문
A급 기기 (업무용 방송통신기자재)	이 기기는 업무용(A급) 전자파적합기기로서 판매자 또는 사용자는 이 점을 주의하시기 바라며, 가정외의 지역에서 사용하는 것을 목적으로 합니다.

# Device Connectivity

## What's in This Chapter

System Design..... 16

## System Design

This product is an operator terminal used for machines or system automation. This section describes the system configuration with this product and peripheral equipment.

**NOTE:** HMIET6401 and HMIET6501 do not have Ethernet or USB (Type A) interfaces.

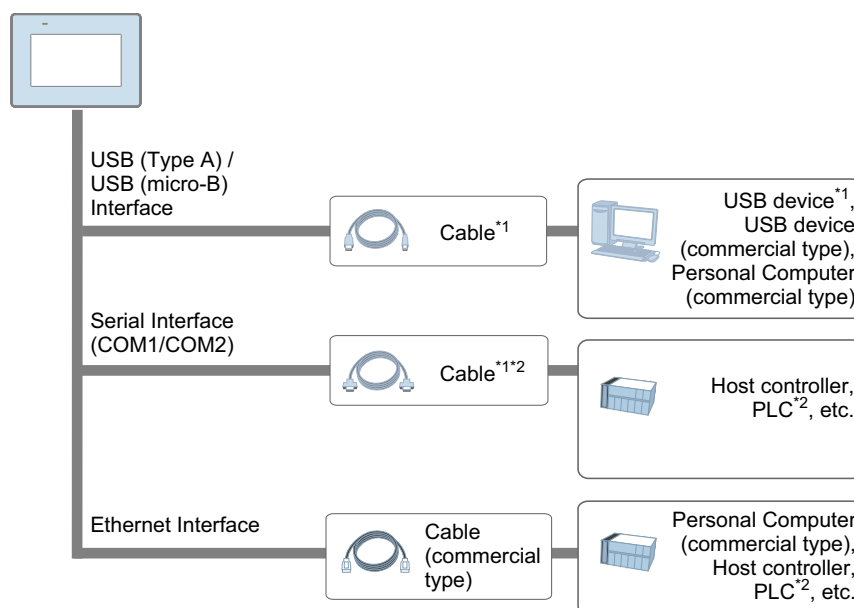

\*1 Refer to Accessories.

\*2 For information on how to connect controllers and other types of equipment, refer to the corresponding device driver manual of your screen editing software.

# Parts Identification and Functions

## What's in This Chapter

Parts Identification..... 17  
 LED Indications..... 19

## Parts Identification

HMIET6400E and HMIET6500E

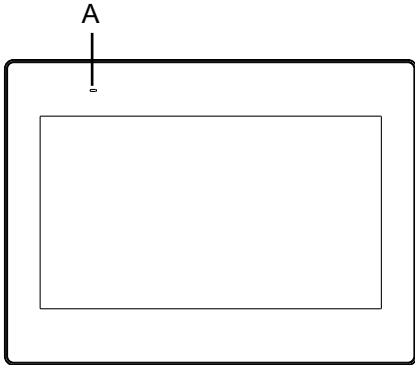
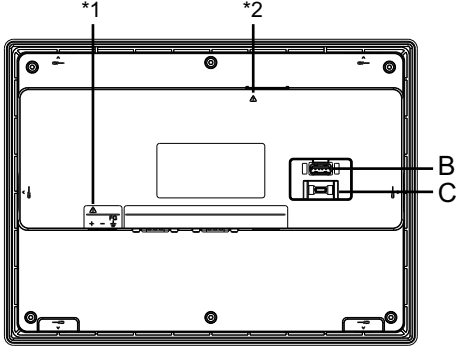
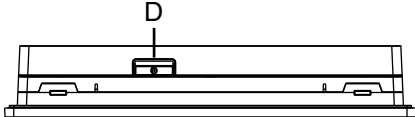
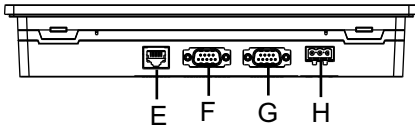
<p>Front</p>	
<p>Rear</p>	
<p>Top</p>	
<p>Bottom</p>	

- A. Status LED
- B. USB (Type A) interface

- C. USB (micro-B) interface
- D. Battery slot
- E. Ethernet interface
- F. Serial interface (COM2)
- G. Serial interface (COM1)
- H. Power connector

\*1 This mark indicates the safety messages about the power wiring. Refer to Wiring the Power Supply, page 36.

\*2 This mark identifies the safety messages about the battery. Refer to Replacing the Battery, page 45.

HMIET6401E and HMIET6501E

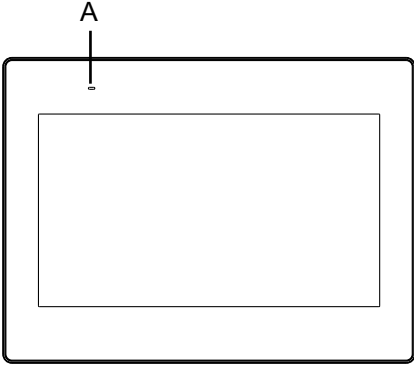
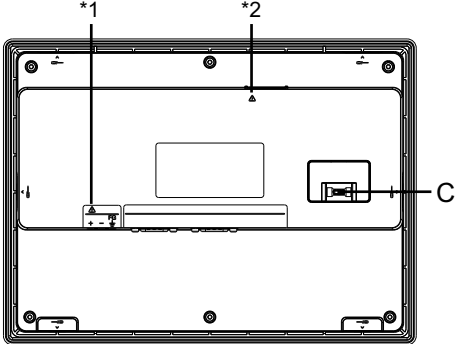
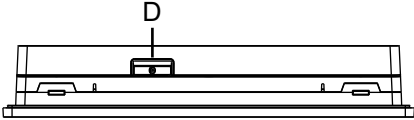
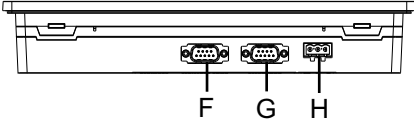
<p>Front</p>	
<p>Rear</p>	
<p>Top</p>	
<p>Bottom</p>	

A. Status LED

- C. USB (micro-B) interface
- D. Battery slot
- F. Serial interface (COM2)
- G. Serial interface (COM1)
- H. Power connector

\*1 This mark indicates the safety messages about the power wiring. Refer to Wiring the Power Supply, page 36.

\*2 This mark identifies the safety messages about the battery. Refer to Replacing the Battery, page 45.

## LED Indications

### Status LED

Color	Indicator	HMI operation
Green	ON	In operation
Orange	ON	Software starting up
Red	ON	Power is ON.
-	OFF	Power is OFF.

### Ethernet LED

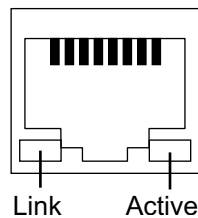

Color	Indicator	Description
Green (Link)	ON	Data transmission is available.
	OFF	No connection or error
Green (Active)	Flashing	Data transmission is occurring.
	OFF	No data transmission

# Specifications

## What's in This Chapter

General Specifications .....	20
Functional Specifications .....	23
Interface Specifications .....	25

## General Specifications

### Electrical Specifications

Rated input voltage	24 Vdc
Input voltage limits	19.2...28.8 Vdc
Voltage drop (at rated input voltage)	5 ms or less
Power consumption	HMIET6400E/HMIET6401E: 9 W HMIET6500E/HMIET6501E: 11 W
In-rush current	30 A or less
Noise immunity	Noise voltage: 1,000 Vp-p Pulse duration: 1 $\mu$ s Rise time: 1 ns (via noise simulator)
Dielectric strength	1,000 Vac for 1 minute (between power terminal and FG terminal)
Insulation resistance	500 Vdc, 10 M $\Omega$ or more (between power terminal and FG terminals)

## Environmental Specifications

Use and store this product in areas that conform to the specified conditions.

**NOTE:** When using any of the options for this product, check the specifications for special conditions or cautions that may apply to this product.

Physical environment	
Ambient air temperature	0...50 °C (32...122 °F)
Storage temperature	-20...60 °C (-4...140 °F)
Ambient air and storage humidity	10...90% RH (non-condensing, wet bulb temperature 39 °C [102.2 °F] or less)
Dust	0.1 mg/m <sup>3</sup> (10 <sup>-7</sup> oz/ft <sup>3</sup> ) or less (non-conductive levels)
Pollution degree	For use in Pollution Degree 2 environment
Corrosive gases	Free of corrosive gases
Atmospheric pressure (operating altitude)	800...1,114 hPa (2,000 m [6,561 ft] or lower)
Mechanical environment	
Vibration resistance	IEC/EN 61131-2 compliant 5...9 Hz Single amplitude 3.5 mm (0.14 in) 9...150 Hz Fixed acceleration: 9.8 m/s <sup>2</sup> X, Y, Z directions for 10 cycles (approximately 100 minutes)
Shock resistance	IEC/EN 61131-2 compliant 147 m/s <sup>2</sup> , X, Y, Z directions for 3 times
Electrical environment	

Electrical fast transient/burst immunity	IEC 61000-4-4 2 kV: Power port 1 kV: Signal ports
Electrostatic discharge immunity	Contact discharge method: 6 kV Air discharge method: 8 kV (IEC/EN 61000-4-2 Level 3)

## Air Quality Requirements

Do not operate or store the product where chemicals evaporate, or where chemicals are present in the air:

- Corrosive chemicals: Acids, alkalines, liquids containing salt.
- Flammable chemicals: Organic solvents.

⚠ CAUTION
INOPERATIVE EQUIPMENT
Do not allow water, liquids, metal, and wiring fragments to enter the panel case.
<b>Failure to follow these instructions can result in injury or equipment damage.</b>

## Structural Specifications

HMIET6400E, HMIET6401E, HMIET6500E and HMIET6501E

	HMIET6400E/HMIET6401E	HMIET6500E/HMIET6501E
Grounding	Functional grounding: Grounding resistance of 100 Ω or less, 2 mm <sup>2</sup> (AWG 14) or thicker wire, or your country's applicable standard.	
Cooling method	Natural air circulation	
Structure*1	IP65	
External dimensions (W x H x D)	205.5 x 150.5 x 45 mm (8.09 x 5.92 x 1.77 in)	270.5 x 200.5 x 47 mm (10.65 x 7.89 x 1.85 in)
Panel cut dimension (W x H)	190 x 135 mm (7.48 x 5.31 in) <sup>*2</sup> Panel thickness area: 1.6...5 mm (0.06...0.2 in) <sup>*3</sup>	255 x 185 mm (10.04 x 7.28 in) <sup>*2</sup> Panel thickness area: 1.6...5 mm (0.06...0.2 in) <sup>*3</sup>
Weight	HMIET6400E: 0.61 kg (1.34 lb) HMIET6401E: 0.60 kg (1.32 lb)	HMIET6500E: 0.99 kg (2.18 lb) HMIET6501E: 0.98 kg (2.16 lb)

\*1 The front face of this product, installed in a solid panel, has been tested using conditions equivalent to the standards shown in the specification. Even though this product's level of resistance is equivalent to these standards, oils that should have no effect on this product can possibly harm this product. This can occur in areas where either vaporized oils are present, or where low viscosity cutting oils are allowed to adhere to this product for long periods of time. If this product's front face protection sheet peels off, these conditions can lead to the ingress of oil into this product and separate protection measures are suggested. Also, if non-approved oils are present, they may cause deformation or corrosion of the front panel's cover. Therefore, prior to installing this product, be sure to confirm the type of conditions that will be present in this product 's operating environment.

If the installation gasket is used for a long period of time, or if this product and its gasket are removed from the panel, the original level of protection cannot be kept. To maintain the original protection level, be sure to replace the installation gasket regularly.

\*2 For dimensional tolerance, everything +1/-0 mm (+0.04/-0 in) and R in angle are below R3 (R0.12 in).

\*3 Even if the installation wall thickness is within the recommended range for the “Panel Cut Dimensions”, depending on wall’s material, size, and installation location of this product and other devices, the installation wall could warp. To prevent warping, the installation surface may need to be strengthened.

## ***NOTICE***

### **EQUIPMENT DAMAGE**

- Ensure this product is not in permanent and direct contact with oils.
- Do not press on the display of this product with excessive force or with a hard object.
- Do not press on the touch panel with a pointed object, such as the tip of a mechanical pencil or a screwdriver.
- Do not expose the device to direct sunlight.
- Store this product in areas where temperatures are within the product’s specifications.

**Failure to follow these instructions can result in equipment damage.**

## ***NOTICE***

### **GASKET AGING**

- Inspect the gasket periodically as required by your operating environment.
- Change the gasket at least once a year, or as soon as scratches or dirt become visible.

**Failure to follow these instructions can result in equipment damage.**

# Functional Specifications

## Display Specifications

HMIET6400E, HMIET6401E, HMIET6500E and HMIET6501E

	HMIET6400E HMIET6401E	HMIET6500E HMIET6501E
Display type	TFT Color LCD	
Display size	7" Wide	10.1" Wide
Resolution	800 x 480 pixels	1,024 x 600 pixels
Effective display area (W x H)	154.08 x 85.92 mm (6.07 x 3.38 in)	222.72 x 125.28 mm (8.77 x 4.93 in)
Display colors	16 million colors For details about display colors, refer to the manual of your screen editing software.	
Backlight	White LED (Not replaceable. Please contact your local distributor.)	
Backlight service life	50,000 hours or more (continuous operation at 25 °C [77 °F] before backlight brightness decreases to 25%)	
Brightness control	16 levels (Adjusted with touch panel or software)	

## Touch Panel

Touch panel type	Resistive film (analog)
Touch points	Single touch
Touch panel resolution	1,024 x 1,024
Touch panel service life	1 million times or more

The touch panel does not support multi-touch (two-point touch / multiple-point touch). If you touch multiple points on the touch panel, it may operate as if you touched the center-point of the multiple touches. For example, if you touch two or more points on the touch panel and at the center of the touches is a switch for a drive system, even though you did not directly touch that switch, it may function as if you did.

<b>⚠ WARNING</b>
<b>UNINTENDED EQUIPMENT OPERATION</b>
Do not touch two or more points on the touch panel.
<b>Failure to follow these instructions can result in death, serious injury, or equipment damage.</b>

## Memory

System memory	256 MB (operating system, project data, backup data, and other data)
Backup memory	128 KB
Local Data Storage	32 MB

---

## Clock

±60 seconds per month (deviation at room temperature and power is OFF).

Variations in operating conditions and battery life can cause clock deviations from -380 to +90 seconds per month.

For systems where this level of precision is insufficient, the user should monitor and make adjustments when required.

This product uses a primary battery for data backup of the internal clock. If the battery is depleted, the clock data will be lost.

# Interface Specifications

## Specifications of Each Interface

**NOTE:** HMIET6401 and HMIET6501 do not have Ethernet or USB (Type A) interfaces.

<b>Serial interface COM1</b>	
Asynchronous transmission	RS-232C
Data length	7 or 8 bits
Stop bit	1 or 2 bits
Parity	None, odd, or even
Data transmission speed	2,400...115,200 bps
Connector	D-Sub 9 pin (plug)
<b>Serial interface COM2</b>	
Asynchronous transmission	RS-422/485
Data length	7 or 8 bits
Stop bit	1 or 2 bits
Parity	None, odd, or even
Data transmission speed	2,400...115,200 bps, 187,500 bps (MPI)
Connector	D-Sub 9 pin (plug)
<b>USB (Type A) interface</b>	
Connector	USB 2.0 (Type A) x 1
Power supply voltage	5 Vdc ±5%
Maximum current supplied	500 mA
Maximum transmission distance	3 m (9.84 ft) at 1.5/12/480 Mbps
<b>USB (micro-B) interface</b>	
Connector	USB 2.0 (micro-B) x 1
Maximum transmission distance	3 m (9.84 ft) at 1.5/12/480 Mbps
<b>Ethernet interface</b>	
Standard	IEEE802.3i/IEEE802.3u, 10BASE-T/100BASE-TX
Connector	Modular jack (RJ-45) x 1

## Serial Interface

The serial interface is not isolated. The SG (signal ground) and FG (frame ground) terminals are separated inside this product.

**⚡⚠ DANGER****ELECTRIC SHOCK AND FIRE**

When using the SG terminal to connect an external device to this product:

- Verify that a ground loop is not created when you set up the system.
- Connect the SG terminal to remote equipment when the external device is not isolated.
- Connect the SG terminal to a known reliable ground connection to reduce the risk of damaging the circuit.

**Failure to follow these instructions will result in death or serious injury.**

**⚠ CAUTION****LOSS OF COMMUNICATION**

- Do not put excessive stress on the communication ports of all connections.
- Securely attach communication cables to the panel wall or cabinet.
- Use a D-Sub 9 pin connector that has jack screws.

**Failure to follow these instructions can result in injury or equipment damage.**

**NOTE:** Use within the rated current.

**Serial Interface COM1 RS-232C**

D-Sub 9 pin plug connector

Product side:

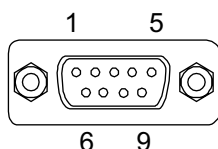

Pin No.	RS-232C		
	Signal name	Direction	Description
1	CD	Input	Carrier Detect
2	RD (RXD)	Input	Receive Data
3	SD (TXD)	Output	Send Data
4	ER (DTR)	Output	Data Terminal Ready
5	SG	-	Signal Ground
6	DR (DSR)	Input	Data Set Ready
7	RS (RTS)	Output	Request To Send
8	CS (CTS)	Input	Clear To Send
9	NC	-	No connection
Shell	FG	-	Functional Ground

Recommended jack screw is #4-40 (UNC).

## Serial Interface COM2 RS-422/485

D-Sub 9 pin plug connector

Product side:

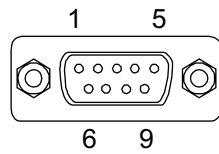

Pin No.	RS-422/RS-485		
	Signal name	Direction	Description
1	RDA	Input	Receive Data A (+)
2	RDB	Input	Receive Data B (-)
3	SDA	Output	Send Data A (+)
4	NC	-	No connection
5	SG	-	Signal Ground
6	NC	-	No connection
7	SDB	Output	Send Data B (-)
8	NC	-	No connection
9	NC	-	No connection
Shell	FG	-	Functional Ground

Recommended jack screw is #4-40 (UNC).

# Dimensions

## What's in This Chapter

HMIET6400E and HMIET6401E External Dimensions .....28  
 HMIET6500E and HMIET6501E External Dimensions .....29

## HMIET6400E and HMIET6401E External Dimensions

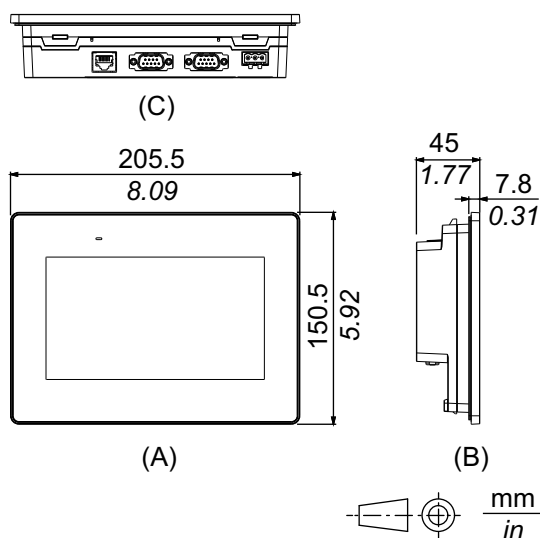

- A. Front
- B. Left
- C. Bottom

# HMIET6500E and HMIET6501E External Dimensions

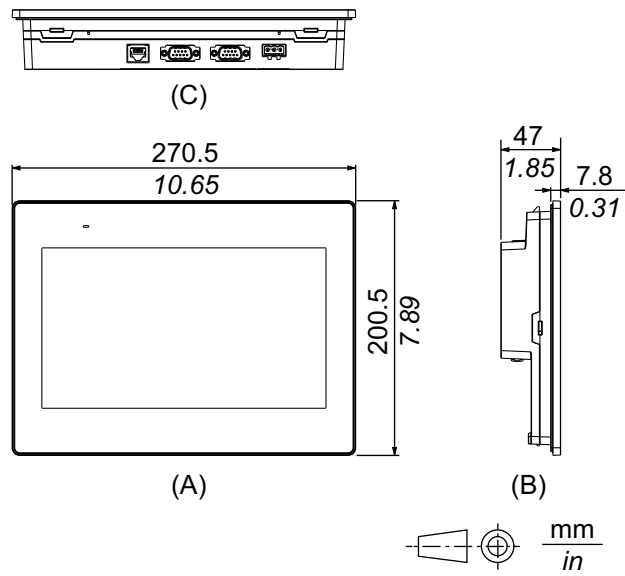

- A. Front
- B. Left
- C. Bottom

# Installing and Wiring

## What's in This Chapter

Installation .....	30
Wiring the Power Supply .....	36
USB Cable Clamp .....	41

## Installation

### Precautions for Building into an End-use Product

This product is designed for use on flat surfaces of enclosures. For HMIET6400E, HMIET6401E, HMIET6500E and HMIET6501E, the front surface is rated for IP65 enclosure.

Be aware of the following when building this product into an end-use product:

- The rear face of this product is not approved as an enclosure. When building this product into an end-use product, be sure to use an enclosure that satisfies standards as the end-use product's overall enclosure.
- Install this product in an enclosure with mechanical rigidity.
- This product is not designed for outdoor use. UL certification obtained is for indoor use only.
- Install and operate this product with its front panel facing outward.

**NOTE:** IP65 is not part of the UL certification.

### Installation Requirements

- Check that the installation wall or cabinet surface is flat, in good condition and has no jagged edges. Metal reinforcing strips may be attached to the inside of the wall, near the panel-cut, to increase its rigidity.
- Decide on the thickness of the enclosure wall, based on the level of strength required. Even if the installation wall thickness is within the recommended range for the Panel Cut Dimensions, depending on wall's material, size, and installation location of this product and other devices, the installation wall could warp. To prevent warping, the installation surface may need to be strengthened.
- Check that the ambient air temperature and the ambient humidity are within their specified ranges in *Environmental Specifications*, page 20. When installing this product in a cabinet or enclosure, the ambient air temperature is the cabinet's or enclosure's internal and external temperature.

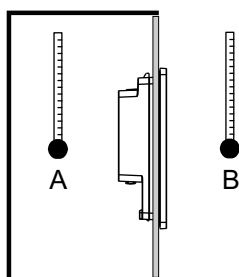

- A. Internal temperature
- B. External temperature

- Be sure that heat from surrounding equipment does not cause this product to exceed its standard operating temperature.
- When mounting this product in portrait orientation, ensure that the right side of this product faces up. In other words, the DC power connector should be at the top.

**NOTE:** For portrait orientation mounting, make sure your screen editing software supports the function.

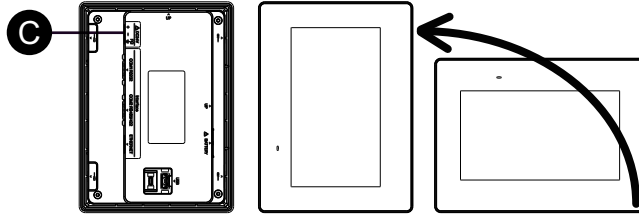

C. Power connector

- When installing this product in a slanted position, the product face should not incline more than 30°.

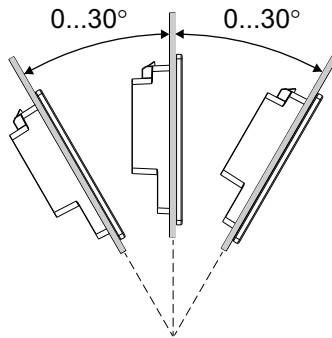

- For easier maintenance, operation and improved ventilation, install this product at least 100 mm (3.94 in) away from adjacent structures and other equipment as shown in the following illustration:

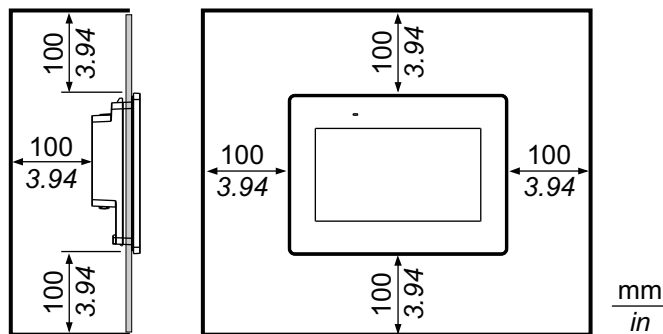

## Pressure Differences

When applying and installing this product, it is important that steps are taken to eliminate any pressure difference between the inside and the outside of the enclosure in which this product is mounted. Higher pressure inside the enclosure can cause delamination of the front membrane of the display. Even a small pressure difference inside the enclosure will act on the large area of the membrane and can result in sufficient force to delaminate the membrane and thus cause failure of the touch capability. Pressure differences can often occur in

applications where there are multiple fans and ventilators moving air at different rates in different rooms. Please follow these techniques to ensure that this product's function is not impacted by this mis-application:

1. Seal all conduit connections inside of the enclosure, especially those that lead to other rooms that may be at a different pressure.
2. Where applicable, install a small weep hole at the bottom of the enclosure to allow equalization of the internal and external pressure.

## Panel Cut Dimensions

Based on the panel cut dimensions, open a mount hole on the panel.

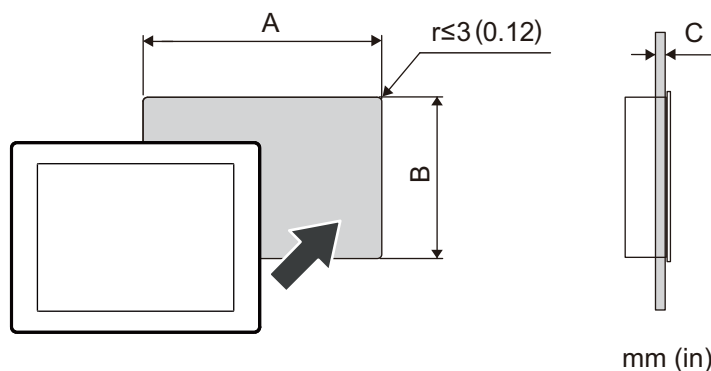

Model Name		
A	B	C
<b>HMIET6400E/HMIET6401E</b>		
190 mm (+1/-0 mm) (7.45 in [+0.04/-0 in])	135 mm (+1/-0 mm) (5.31 in [+0.04/-0 in])	1.6...5 mm (0.06...0.2 in)
<b>HMIET6500E/HMIET6501E</b>		
255 mm (+1/-0 mm) (10.04 in [+0.04/-0 in])	185 mm (+1/-0 mm) (7.28 in [+0.04/-0 in])	1.6...5 mm (0.06...0.2 in)

## Installation Procedure

This section describes how to install this product to the panel.

### **⚠️ ⚠️ DANGER**

#### **HAZARD OF ELECTRIC SHOCK, EXPLOSION, OR ARC FLASH**

- Remove all power from the device before removing any covers or elements of the system, and prior to installing or removing any accessories, hardware, or cables.
- Unplug the power cable from both this product and the power supply prior to installing the product.
- Always use a properly rated voltage sensing device to confirm power is off where and when indicated.
- Replace and secure all covers or elements of the system before applying power to this product.

**Failure to follow these instructions will result in death or serious injury.**

## NOTICE

### EQUIPMENT DAMAGE

- Always use the installation gasket.
- Keep panel stabilized in the panel-cut while you are installing or removing the screw fasteners.

**Failure to follow these instructions can result in equipment damage.**

1. Place this product on a clean and level surface with the screen facing down.
2. Check that the gasket is seated securely into the bezel groove, which runs around the perimeter of the display panel frame.

**NOTE:** Always use the installation gasket, since it absorbs vibration in addition to repelling water.

3. Based on this product's Panel Cut Dimensions, page 32, open a mount-hole on the panel.

**NOTE:** This product has a hook on the top to prevent falling during installation. Insert this product into the panel at an angle to avoid hitting the hook.

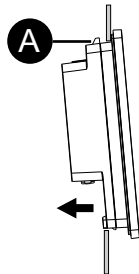

A. Hook

4. Insert the installation fasteners into the panel's insertion slots of this product.

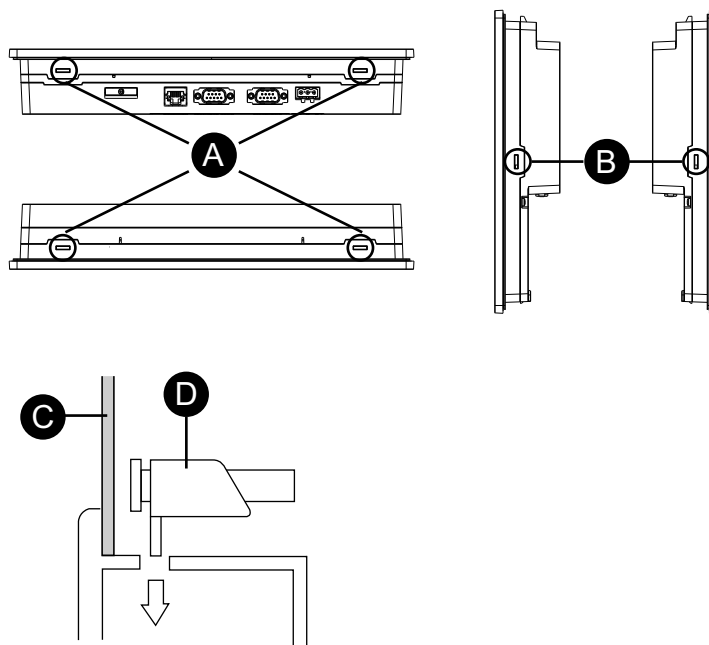

- A. Insertion slots
- B. Insertion slots (except for the HMIET6400E/HMIET6401E)
- C. Panel
- D. Installation fastener for HMIET6400E/HMIET6401E, HMIET6500E/HMIET6501E

The number of installation fasteners for each model is as follows.

HMIET6400E/HMIET6401E	Top - 2, Bottom - 2
HMIET6500E/HMIET6501E	Top - 2, Bottom - 2, Left - 1, Right - 1

5. Tighten the installation fastener's screws with a screwdriver.

**NOTE:**

- The necessary torque is 0.5 N•m (4.4 lb-in).
- If the fasteners are not correctly attached, the panel may shift or fall out.

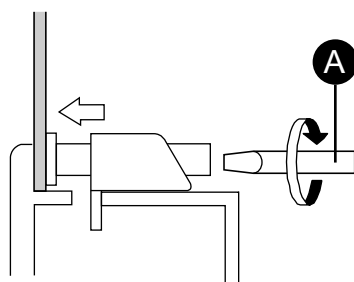

- A. Screwdriver

## Removal Procedure

This section describes how to remove this product from the panel.

### **⚠️⚠️ DANGER**

#### **HAZARD OF ELECTRIC SHOCK, EXPLOSION, OR ARC FLASH**

- Remove all power from the device before removing any covers or elements of the system, and prior to installing or removing any accessories, hardware, or cables.
- Unplug the power cable from both this product and the power supply prior to removing the product.
- Always use a properly rated voltage sensing device to confirm power is off where and when indicated.

**Failure to follow these instructions will result in death or serious injury.**

### **⚠️ CAUTION**

#### **RISK OF INJURY**

Do not drop this product when you remove it from the panel.

- Hold this product in place after removing the fasteners.
- Use both hands.
- While pushing on the hook, be careful not to hurt your fingers.

**Failure to follow these instructions can result in injury or equipment damage.**

### **NOTICE**

#### **EQUIPMENT DAMAGE**

Keep this product stabilized in the panel-cut while you are installing or removing the screw fasteners.

**Failure to follow these instructions can result in equipment damage.**

1. Loosen the screws of the installation fasteners, remove the product slowly from the panel.

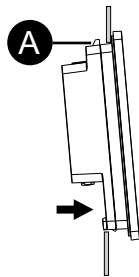

A. Hook

# Wiring the Power Supply

## DC Power Cord Preparation

### ⚠ CAUTION

#### WIRING REQUIREMENT

- Make sure the ground wire is either the same or heavier gauge than the power wires.
- Do not use aluminum wires in the power supply's power cord.
- If the ends of the individual wires are not twisted correctly, the wires may create a short circuit.
- The conductor type is solid or stranded wire.
- Use copper wire rated for 75 °C (167 °F) or higher.
- Use the SELV (Safety Extra-Low Voltage) circuit and LIM (Limited Energy) circuit for DC input.

**Failure to follow these instructions can result in injury or equipment damage.**

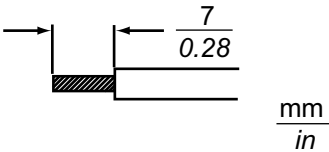
Power cord diameter	0.75...2.5 mm <sup>2</sup> (18...13 AWG)* <sup>1</sup>
Conductor type	Solid or stranded wire
Conductor length	
Recommended driver	Flat-head screwdriver (size 0.6 x 3.5)

\*<sup>1</sup> For UL compatibility, use AWG 14 or AWG 13.

## How to Connect the DC Power Cord

### ⚡⚠ DANGER

#### HAZARD OF ELECTRIC SHOCK, EXPLOSION, OR ARC FLASH

- Remove all power from the device before removing any covers or elements of the system, and prior to installing or removing any accessories, hardware, or cables.
- Remove power before wiring this product's power terminals.
- Always use a properly rated voltage sensing device to confirm power is off where and when indicated.
- Replace and secure all covers or elements of the system before applying power to this product.
- Use only the specified voltage when operating this product. This product is designed to use 24 Vdc. Always check whether your device is DC powered before applying power.
- Since this product is not equipped with a power switch, be sure to connect a power switch to the power supply.
- Be sure to ground this product's FG terminal.

**Failure to follow these instructions will result in death or serious injury.**

**NOTE:**

- The SG (signal ground) and FG (frame ground) terminals are separated inside this product.
- When the FG terminal is connected, be sure the wire is grounded. Not grounding this product can result in excessive electromagnetic interference (EMI).

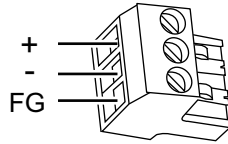
**DC Power Connector**

Connection	Wire
+	24 Vdc
-	0 Vdc
FG	Grounded terminal. Connect the FG terminal properly to ground.

**Connection Procedure**

1. Confirm the power cord is not connected to the power supply.
2. Check the rated voltage.
3. Strip the membrane of the power cord, and twist the wire ends.
4. Insert each power cord wire into its corresponding hole. Fasten the screws of the DC power connector to clamp the wire in place.

**NOTE:**

- The necessary torque is 0.56 N•m (5 lb-in).
- Do not solder the stranded wires.

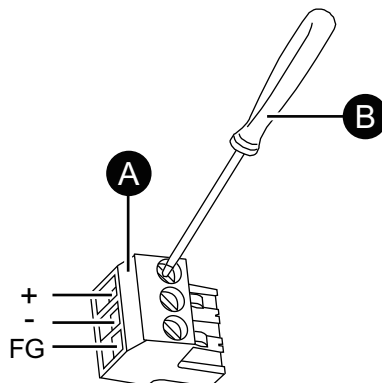

- A. DC power connector
- B. Flat-blade screwdriver (size 0.6 x 3.5)

5. After inserting all three power cord wires, insert the DC power connector into the power connector on this product.

## Power Supply Precautions

### **⚡⚠ DANGER**

#### **SHORT CIRCUIT, FIRE, OR UNINTENDED EQUIPMENT OPERATION**

- Install and fasten this product in an installation panel or cabinet prior to connecting power supply and communication lines.
- Securely attach power cables to an installation panel or cabinet.
- Avoid excessive force on the power cable.

**Failure to follow these instructions will result in death or serious injury.**

## Improving Noise/Surge Resistance

- This product's power cord should not be bundled with or kept close to main circuit lines (high voltage, high current), power lines, or input/output lines, and their various systems should be kept separate. When power lines cannot be wired via a separate system, use shielded cables for input/output lines.
- Make the power cord as short as possible, and be sure to twist the ends of the wires together (i.e. twisted pair cabling) from close to the power supply unit.
- If there is an excess amount of noise on the power supply line, connect a noise reducing transformer, noise filter, or other before turning on the power.
- Connect a surge protection device to handle power surges.
- To increase noise resistance, attach a ferrite core to the power cable.

## Power Supply Connections

- When supplying power to this product, connect the power as shown below.

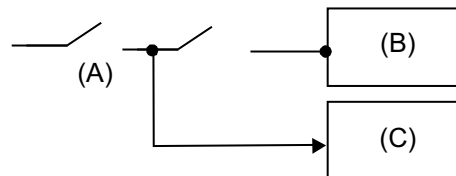

- A. Main power
- B. This product
- C. Other unit

- Use the SELV (Safety Extra-Low Voltage) circuit and LIM (Limited Energy) circuit for DC input.

- The following shows a surge protection device connection:

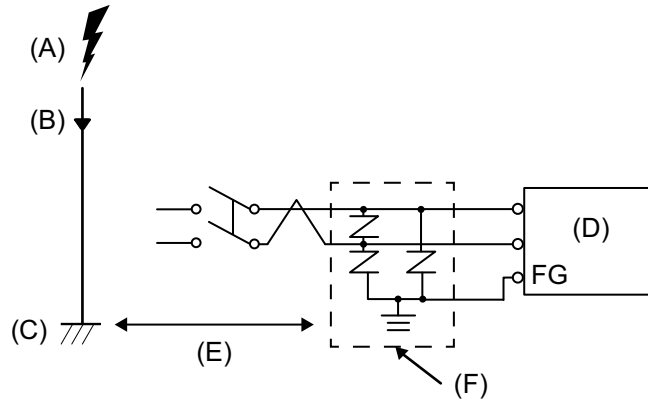

- A. Lightning
  - B. Lightning rod
  - C. Ground
  - D. This product
  - E. Provide adequate distance
  - F. Surge protection device
- Attach a surge protection device to prevent damage to this product as a result of a lightning-induced power surge from a large electromagnetic field generated from a direct lightning strike. We also strongly recommend to connect the crossover grounding wire of this product to a position close to the ground terminal of the surge protection device.  
 It is expected that there will be an effect on this product due to fluctuations in grounding potential when there is a large surge flow of electrical energy to the lightning rod ground at the time of a lightning strike. Provide adequate distance between the lightning rod grounding point and the surge protection device grounding point.
  - If the voltage variation is outside the prescribed range, connect a regulated power supply.

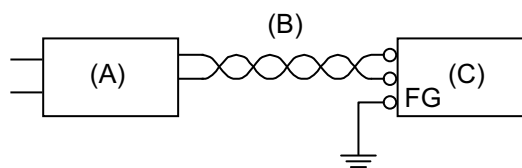

- A. Regulated power supply
- B. Twisted-pair cord
- C. This product

## Grounding

### Independent Grounding

Always ground the FG (functional ground) terminal. Be sure to separate this product from the FG of other devices as shown below.

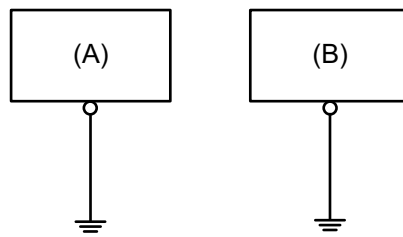

- A. This product
- B. Other equipment

## Precautions

- Check that the grounding resistance is 100  $\Omega$  or less.\*1
- The FG wire should have a cross sectional area 2 mm<sup>2</sup> (AWG14) or greater\*1. Create the connection point as close as possible to this product, and make the wire as short as possible. When using a long grounding wire, replace the thin wire with a thicker wire, and place it in a duct.
- The SG (signal ground) and FG (frame ground) terminals are connected internally in this product. When connecting the SG line to another device, be sure that no ground loop is formed.

\*1 Observe local codes and standards.

## Common Grounding

Electromagnetic Interference (EMI) can be created if devices are improperly grounded. EMI can cause loss of communication. If exclusive grounding is not possible, use a common grounding point as shown in the configuration below. Do not use any other configuration for common grounding.

Correct grounding

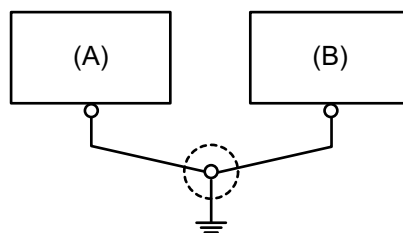

- A. This product
  - B. Other equipment
- Incorrect grounding

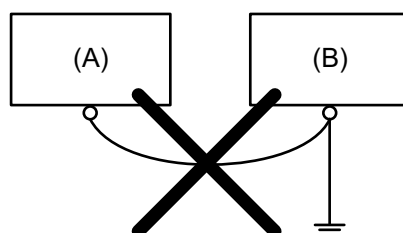

- A. This product
- B. Other equipment

# USB Cable Clamp

## Attaching USB Clamp Type A

When using a USB device, attach a USB cable clamp to the USB interface to prevent the USB cable from being disconnected.

### ⚠ DANGER

#### EXPLOSION HAZARD

- Do not disconnect equipment while the circuit is live or unless the area is known to be free of ignitable concentrations.
- Remove power before attaching or detaching any connectors to or from this product.
- Ensure that power, communication, and accessory connections do not place excessive stress on the ports. Consider the vibration in the environment when making this determination.
- Securely attach power, communication, and external accessory cables to the panel or cabinet.
- Use only commercially available USB cables.
- Use only non-incendive USB configurations.
- Do not use the USB interface in hazardous locations.
- Confirm that the USB cable has been attached with the USB cable clamp before using the USB interface.

**Failure to follow these instructions will result in death or serious injury.**

**NOTE:** Watch your fingers. The edge of the clip is sharp.

1. Mount the clip to the USB mark  connector shell so that it overlaps. The clip matches the 27 to 43.5 mm (1.06 to 1.71 in) length of the USB connector.

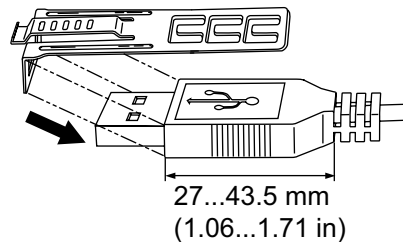

2. Align the clip and the USB cable connector shell. Adjust the position of the holes where the clip is attached. To ensure stability, select the clip-hole position that is closest to the base of the connector shell.

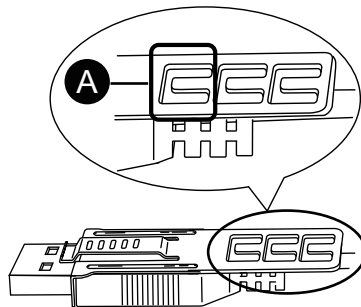

A. Hole for tie to pass through

- As shown, pass the tie through the clip hole. Next, turn the tie and pass it through the head so that the USB cable can pass through the center of the tie loop. The clip is now attached to the USB cable.

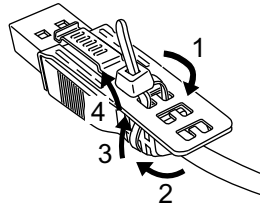

**NOTE:**

- Check the direction of the head beforehand. Make sure the USB cable is through the center of the tie loop and that the tie can pass through the head.
  - You can substitute the tie provided with HMIZGCLP1, or other commercially available ties with a width of 4.8 mm (0.19 in) and thickness of 1.3 mm (0.05 in).
- While pressing the grip on the clip, insert the cable from step 3 all the way into the USB host interface. Make sure that the clip tab is secured to the USB cable attached to this product.

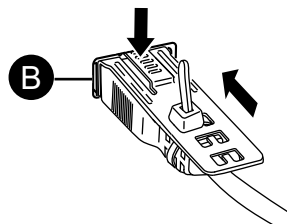

B. USB Type A interface

## Removing USB Clamp Type A

Remove the USB cable while pushing the grip section of the clip.

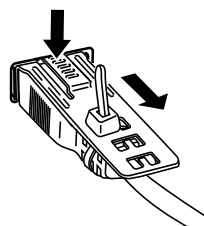

## Attaching USB Clamp mini-B

When using the USB micro-B cable (option), you can use the USB mini-B clamp (sold separately) to prevent the cable from being disconnected.

**⚠ DANGER****EXPLOSION HAZARD**

- Confirm that the USB cable has been fixed with the USB clamp before using the USB interface.
- Remove power before attaching or detaching any connectors to or from this product.
- Use the USB (micro-B) interface for temporary connection only during maintenance and setup of the device.
- Do not use the USB interface in hazardous locations.

**Failure to follow these instructions will result in death or serious injury.**

1. Insert the USB cable into the USB (micro-B) interface.

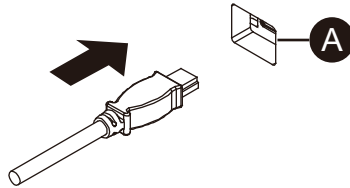

A. USB interface

2. Attach the USB clamp to fix the USB cable in place. Insert the USB holder into the USB (micro-B) interface.

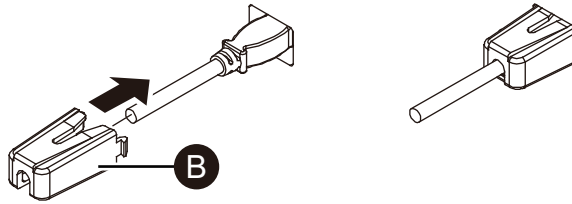

B. USB clamp

## Removing USB Clamp mini-B

Remove the USB clamp by pressing the tabs from the sides.

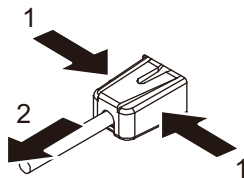

# Maintenance

## What's in This Chapter

Regular Cleaning .....	44
Periodic Check Points.....	44
Replacing the Battery .....	45
Replacing the Backlight .....	46

## Regular Cleaning

### Cleaning the Product

#### **NOTICE**

##### **EQUIPMENT DAMAGE**

- Power off this product before cleaning it.
- Do not use hard or pointed objects to operate the touch panel.
- Do not use paint thinner, organic solvents, or a strong acid compound to clean the unit.

**Failure to follow these instructions can result in equipment damage.**

When this product gets dirty, wipe this product with a soft, dry cloth or a soft cloth soaked in only water and wrung tightly.

**NOTE:** When the product is very dirty, soak the soft cloth in water with a neutral detergent, wring the cloth tightly and wipe the product while avoiding the product label.

## Periodic Check Points

### Operation Environment

- Is the ambient air temperature within the allowable range? Refer to Environmental Specifications, page 20.
- Is the ambient air humidity within the specified range? Refer to Environmental Specifications, page 20.

When this product is inside a panel, the ambient environment refers to the interior of the panel.

## Electrical Specifications

- Is the input voltage appropriate? Refer to Electrical Specifications, page 20.
- Are all power cords and cables connected properly? Are there any loose cables?
- Are all mounting brackets holding the unit securely?
- Are there scratches or traces of dirt on the installation gasket?

## Unit Disposal

When disposing this product, dispose it in a manner appropriate to, and in accordance with, your country's industrial machinery disposal/recycling standards.

## Replacing the Battery

### Introduction

The primary battery is non-rechargeable, and is used for data backup of memory and the internal clock. If the primary battery is depleted, the backup data is lost. Use only the replacement battery (HMIZSBA1) or a commercially available battery (CR2032) for this product.

### **DANGER**

#### **HAZARD OF ELECTRIC SHOCK, EXPLOSION, OR ARC FLASH**

- Follow the procedures step by step to replace the battery correctly and safely.
- Before replacing the battery, turn off this product's power.

**Failure to follow these instructions will result in death or serious injury.**

### **DANGER**

#### **EXPLOSION, FIRE, OR CHEMICAL HAZARD**

- Use only the identical replacement battery for this product.
- Do not cause a short circuit.
- Recycle or properly dispose of used batteries.
- Do not recharge, disassemble or heat above 70 °C (158 °F).
- Use your hands or insulated tools to remove or replace the battery.
- Maintain proper polarity when inserting and connecting a new battery.

**Failure to follow these instructions will result in death or serious injury.**

### **NOTICE**

#### **LOSS OF DATA**

- Replace the battery regularly every five years after you purchase this product.
- Allow only qualified personnel to change the battery.

**Failure to follow these instructions can result in equipment damage.**

**NOTE:** The product contains cells and/or storage batteries which must be collected and processed separately when they have run out and at the end of product life. When disposing the battery dispose it in a manner appropriate to, and in accordance with, your country's industrial machinery disposal/recycling standards.

1. Disconnect the power supply from this product.
2. Touch the housing or ground connection to discharge any electrostatic charge from your body.
3. Place this product on a flat, level surface, with the front side pointing up.

4. Open the battery slot on the top or bottom of this product.

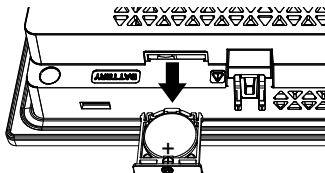

1. Battery slot
2. Safety alert symbol (see the safety messages stated on the previous page)
5. Remove the spent battery from the tray by touching the battery from the bottom.

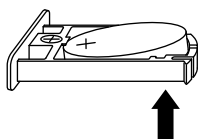

6. Put the new battery on the tray in accordance with the polarity markings in the tray and on the battery.
7. Insert the tray into the battery slot.
8. Reconnect the power supply to this product.

**NOTE:** After reconnecting the power supply, set up the clock again. Refer to your screen editing software manual on how to set up the clock.

## Replacing the Backlight

Not replaceable. Please contact your local distributor.



Eliwell Controls s.r.l.  
Via dell'Industria, 15 • Zona Industriale Paludi  
32016 Alpago (BL)  
Italy

+39 0437 166 0000

+39 0437 166 0060 (Italy)

+39 0437 166 0066 (other countries)

+39 0437 166 0005 (Technical Helpline)

[www.eliwell.com](http://www.eliwell.com)

As standards, specifications, and design change from time to time, please ask for confirmation of the information given in this publication.

© 2025 – Eliwell. All rights reserved.

9MA10321.00